

标准型 /standard

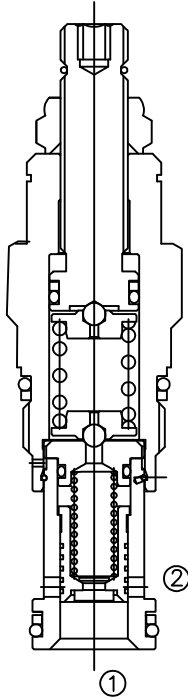

HSRPGE

先导式溢流阀

Pilot-Operated, Balanced Piston Relief Valve

OPERATION

工作原理

The valves are normally closed, pressure-limiting valves used to protect hydraulics components from pressure transients. Fast opening and closing is gained at the expense of smoothness. When the pressure at the inlet (port ①) reaches the valve setting, the valve starts to open to tank (port ②), throttling flow to limit the pressure rise. These valves have low pressure rise vs. flow and are very fast. Back pressure on the tank port ② is directly additive to the valve setting at a 1:1 ratio.

快速响应先导式滑阀型溢流阀用于保护系统的压力瞬时过载，快速启闭时仍能保持系统平稳性。当①口压力超过阀的设定时，①口到②口溢流过载，限制系统压力升高，该阀对压力反应灵敏。②口背压会按 1:1 叠加到阀的设定压力上。

SYMBOL 机能符号

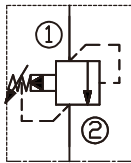

FEATURES

特性

- Fast response to pressure surges 迅速响应压力变化
- Hardened poppet and seat for long life 长寿命的阀
- Industry common cavity 工业通用插孔
- Compact size 紧凑结构
- Not suitable for use in load holding applications due to spool leakage. 不适合用在保压系统中

PRESSURE DROP VS.FLOW 性能图

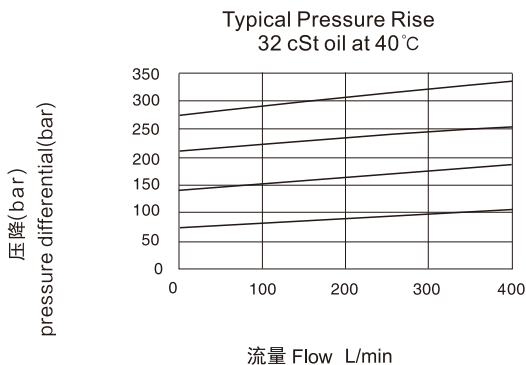

SPECIFICATIONS

技术参数

最大工作压力 (Max. Operating Pressure): 350Bar

流量 Flow rate(L/min): 参见性能图 See Pressure Drop VS.Flow graph.

内泄漏 Internal Leakage: 30ml/min. at 70bar

Factory Pressure Setting Established at 4gpm(15l/min)

工厂的设定是指溢流阀开启时（流量为 15L/min）的压力

弹簧调压范围 : (Standard Spring Ranges):

A 7 to 210 bar	Preset=70Bar
B 3.5 to 105 bar	Preset=70Bar
C 10.5 to 420 bar	Preset=70Bar
D 1.7 to 55bar	Preset=30Bar
E 1.7 to 28 bar	Preset=14Bar
W 10.5 to 315 bar	Preset=70Bar

介质温度 (Fluid temperature range): -30 °C to +120 °C

介质 Fluids: 矿物油。其它流体请咨询工厂。

Mineral-based fluids。

For other fluid compatibility, consult factory。

插孔 Cavity: SUNT-3A

阀块材料 Body Material :

钢材允许使用最大压力 350bar

Steel rated to 350bar

INSTALLATION DIMENSIONS
安装尺寸

Unit=Millimeters

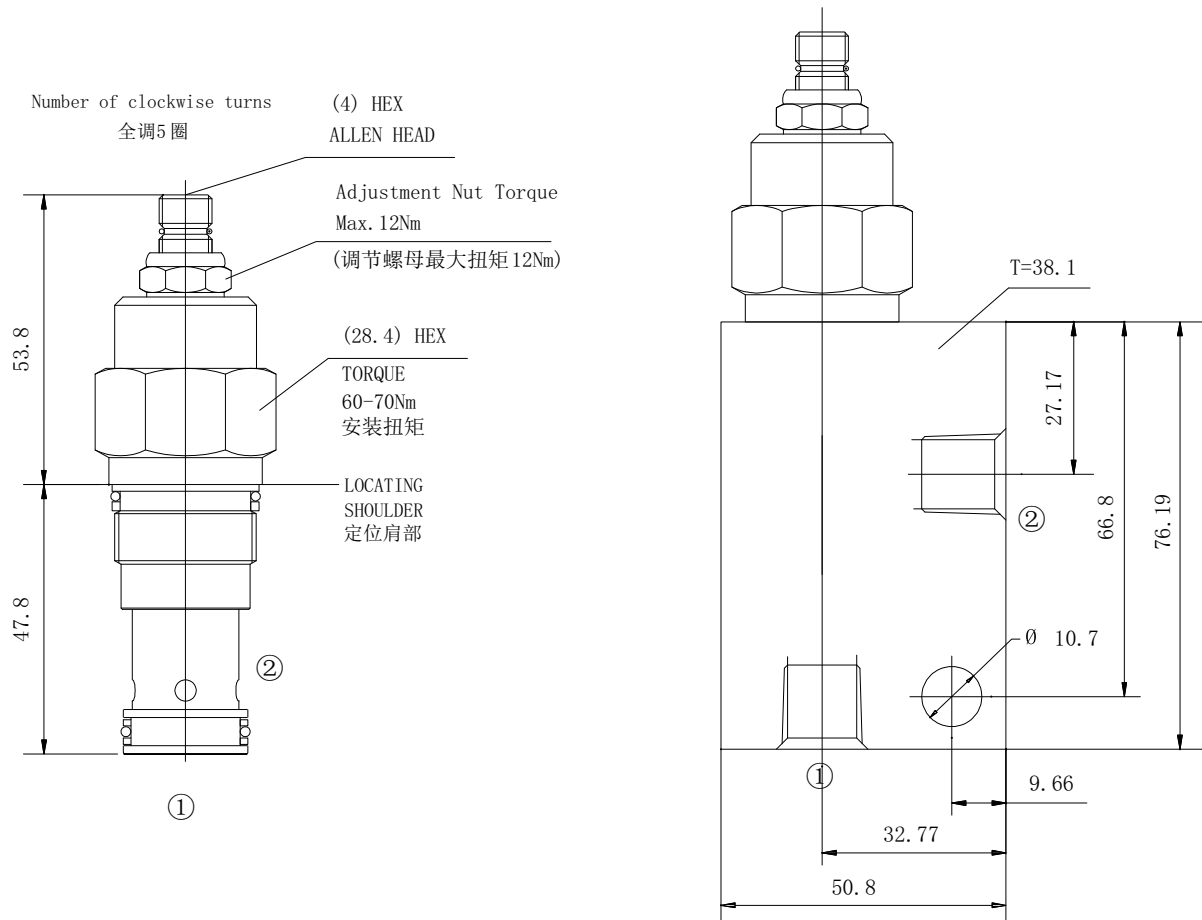

HSRP * E L * N

先导式溢流阀
Pilot-Operated, balanced
piston relief valve

流量: FLOW
G=200L/min

控制方式: CONTROL
L=Standard screw Adjustment 螺杆

密封材料: SEAL KITS
N=BUNA N 丁晴橡胶 (标准型)

弹簧调压范围: SPRING RANGE

A=100~3000psi (7~210bar)	Preset: 1000psi (70bar)
B=50~1500psi (3.5~105bar)	Preset: 1000psi (70bar)
C=150~6000psi (10.5~420bar)	Preset: 1000psi (70bar)
D=25~800psi (1.7~55bar)	Preset: 400psi (30bar)
E=25~400psi (1.7~28bar)	Preset: 200psi (14bar)
W=150~4500psi (10.5~315bar)	Preset: 1000psi (70bar)