

HSFD52-45

分流/集流阀

Flow Dividing/Combining Valve

HSFD52-45是一种螺纹插装式，滑阀型分流/集流阀
The FD52-45 is a screw-in cartridge, spool type flow divider/combiner valve.

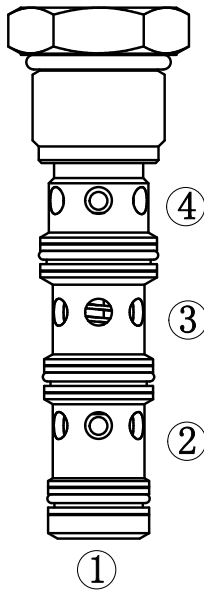

PERATION

工作原理

The cartridge valve pressure compensated proportional division of inlet flow or combining of two return flows regardless of system operating pressure conditions. The valve provides synchronizing flow in dividing and combining modes.

此阀为压力补偿式插装阀，分流或集流与系统压力无关。

FEATURES

特性

- 零件硬质处理，耐用
Hardened parts for long life.
- 安静，响应平稳
Quiet, modulated response.
- 流量范围宽
Wide operating flow range.
- 分流、集流同步
Synchronizing in dividing and combining modes.
- 浮动阀套-高装配扭矩
Floating cage - high installation torque.
- 工业常规阀孔
Industry-common cavity.

SYMBOL

机能符号

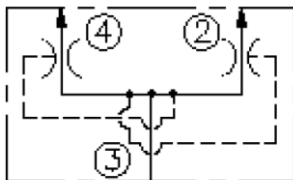

PRESSURE DROP VS.FLOW

性能图

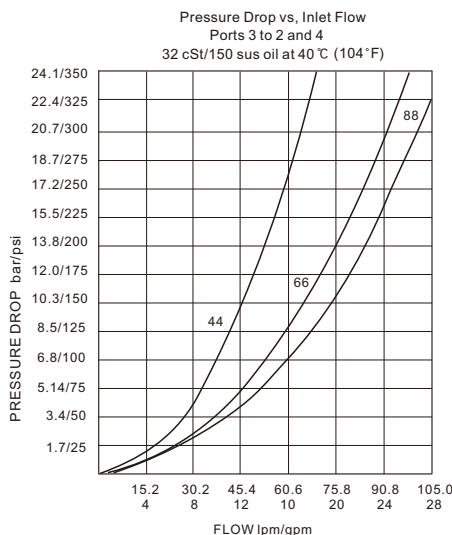

SPECIFICATIONS

技术参数

- 最大工作压力 Max Working Pressure:** 345bar
- 流量Flow Rate:**
- 输入流量Input flow:** 90.8lpm (24gpm) ; 比例Proportion: 50:50; 型号代码Model Code: 66
- 分流精度 Flow accuracy:** 最大输入流量的10%
Approximately 10% of maximum inlet flow
- 温度范围Temperature Range:** -40°C - 120°C
- 过滤Filtration:**
Maximum Operating Contamination Level: 18/16/13 per ISO 4406
- 介质Fluids:**
粘度介于7.4-420cSt (50-2000ssu) 的矿物油或具有润滑作用的合成油
Mineral oil or lubricating synthetic oil with viscosity between 7.4 and 420 CST (50-2000 ssu)
- 插孔Cavity:** 12-4

INSTALLATION DIMENSIONS 安装尺寸

Unit=Millimeters

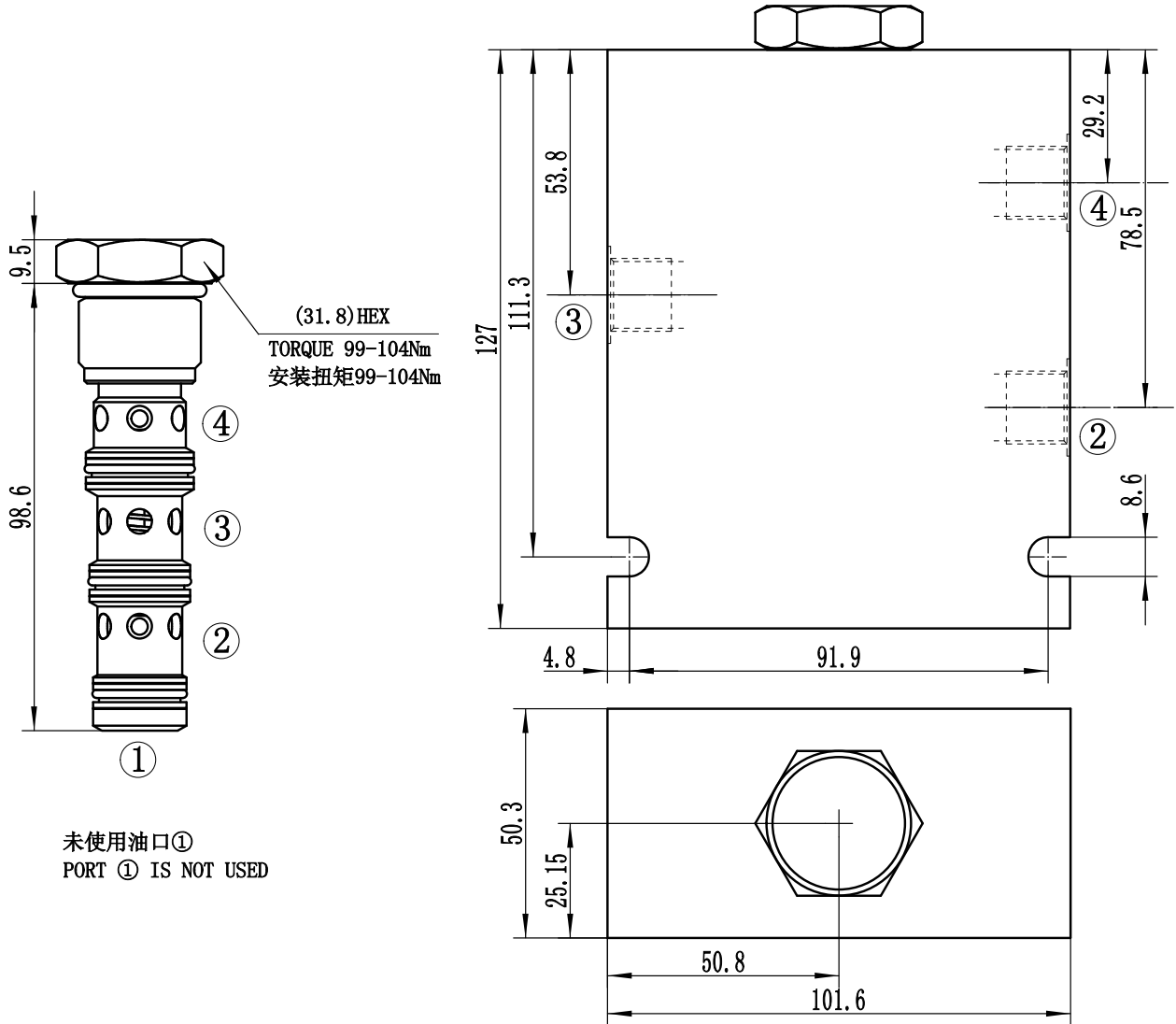

未使用油口①
PORT ① IS NOT USED

HSFD52-45 — * — * — *

BODY PORTING 阀块油口
0=只订购插装件 Only add-ons ordered
SAE10=10T(6061 T6)
SAE12=12T(6061 T6)
SAE8=8TD(45/QT)
SAE10=10TD(45/QT)
铝制阀块最大工作压力240bar
Maximum operating pressure of Aluminium Block 240 bar
钢制和球墨铸铁阀块最大工作压力350bar
Steel and Ductile Iron Valve blocks up to 350 bar

流量选项 (50/50比例)
Flow options (50/50 Ratio)

66 23-90lpm (6-24gpm)

密封材料 Sealing material
N=Nitrile Rubber Buna 丁晴橡胶(标准型)
V=Fluororubber 氟橡胶
P=Polyurethane rubber 聚氨酯橡胶

注: 标准12号四通阀块不能用于分流

Note: Standard 12 four-way block shall not be used for dividing