

标准型 /standard

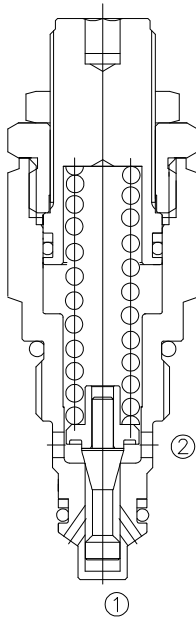

HSRVC0.S10

直动式溢流阀

Adjustable, Direct-Acting
Cartridge Relief Valve

OPERATION

工作原理

The valve prevents flow from ① to ② until the set crack pressure at ① is achieved. The poppet then unseats allowing flow from ① to ② protecting the circuit from over pressurization.

当在①口的压力超过调压弹簧设定的压力时，阀芯打开，①到②通，防止系统过压。

SYMBOL 机能符号

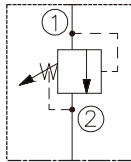

FEATURES

特性

- | | |
|--|----------|
| Fast response to pressure surges | 迅速响应压力变化 |
| Hardened poppet and seat for long life | 长寿命的阀 |
| Industry common cavity | 工业通用插孔 |
| Compact size | 紧凑结构 |
| Quiet response | 无噪音响应 |

PRESSURE DROP VS.FLOW 性能图

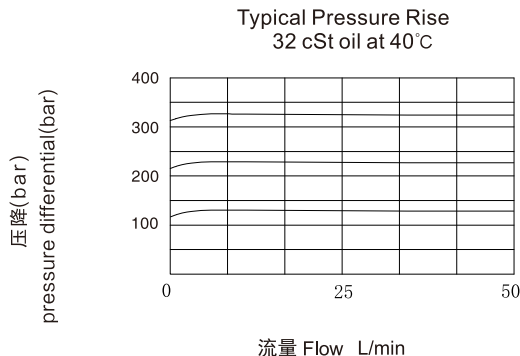

SPECIFICATIONS

技术参数

最大工作压力 (Max. Operating Pressure) : 350Bar

流量 Flow rate(L/min): 参见性能图 See Pressure Drop VS.Flow graph.

内泄漏 Internal Leakage: 5drops/min. MAX.to 80% of normal setting

Reseat Pressure : Nominal 80% of crack pressure

(crack(set)pressure at 5lpm/1.25gpm)

弹簧调压范围 : (Standard Spring Ranges): Y 15 to 60 bar Preset=30Bar
 N 25 to 135 bar Preset=60Bar
 B 50 to 220 bar Preset=110Bar
 G 120 to 350bar Preset=200Bar

介质温度 (Fluid temperature range): -30 ° C to +120 ° C

介质 Fluids: 矿物油。其它流体请咨询工厂。

Mineral-based fluids .

For other fluid compatibility,consult factory .

插孔 Cavity: 10-2

阀块材料 Body Material :

钢材允许使用最大压力 350bar

Steel rated to 350bar

INSTALLATION DIMENSIONS
安装尺寸

Unit=Millimeters

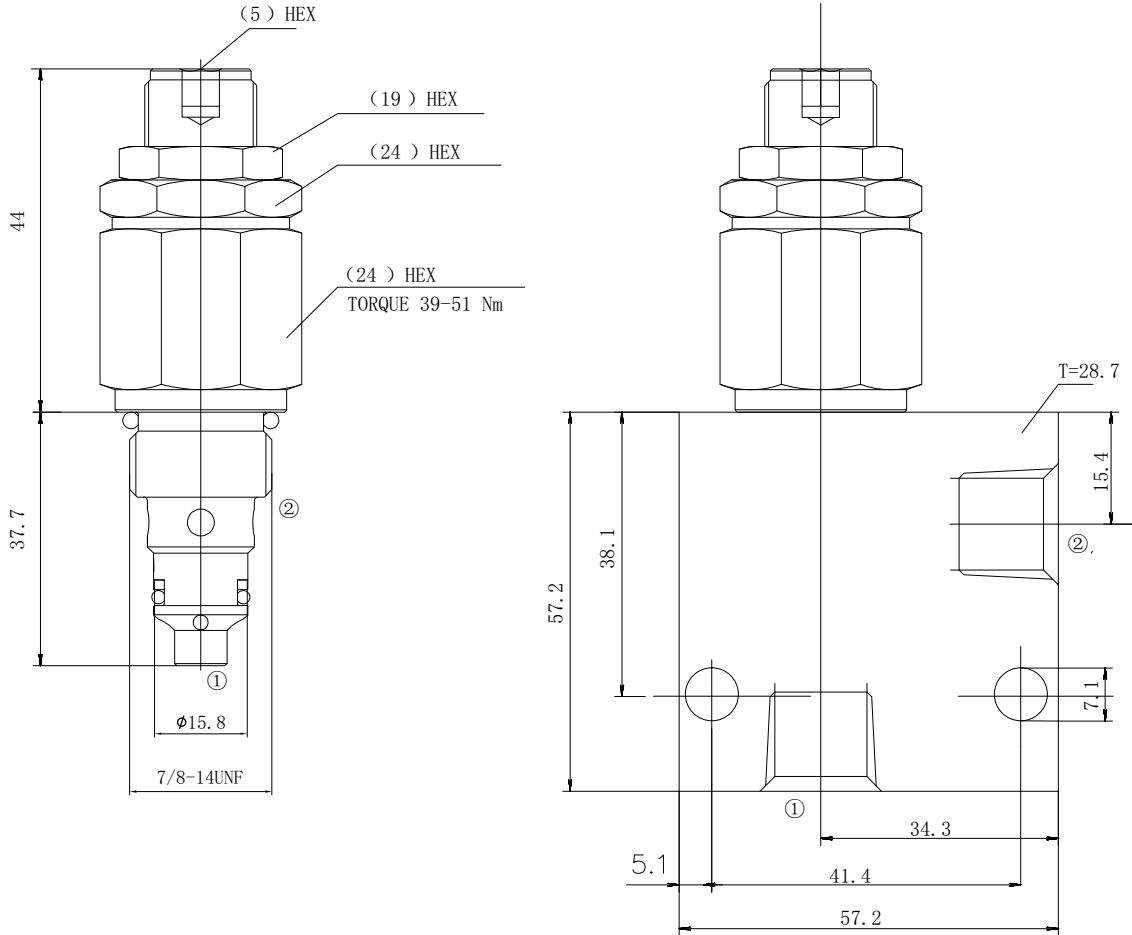

HSRVCO - S10 - 0 - * - * - *

直动式溢流阀
Adjustable, Direct-Acting
Cartridge Relief Valve

插孔: Cavity
S10=7/8-14UNF with 15.8 nose size

弹簧调压范围: SPRING RANGE

Y=220~870psi (15~60bar) preset: 400psi (30bar)
N=360~1950psi (25~135bar) preset: 800psi (60bar)
B=730~3200psi (50~220bar) preset: 1600psi (110bar)
G=1750~5000psi (120~350bar) preset: 2900psi (200bar)

BODY PORTING 阀块油口
6T=SAE6
8T=SAE8
3G=G3/8
4G=G1/2
Other Porting is Available
其它螺纹油口也是可以选择的
(Omit for Cartridge only
省略为不带阀块)

设定压力: Pressure setting in (bar)
00= 无要求; NO specific setting required