

标准型 /standard

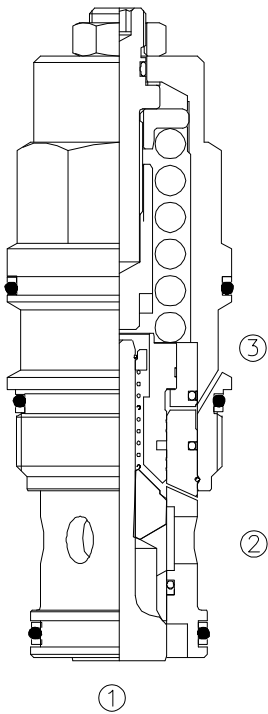

HSCBCA/HSCBCG

平衡阀

Counterbalance Cartridge valve

OPERATION

工作原理

Counterbalance valves with pilot assist are meant for control on overrunning load. The check valve allows free flow from port ② to port ① while a direct-acting, pilot-assisted relief valve controls flow from port ① to port ②. Pilot assist at port ③ lowers the effective setting of the relief valve at a rate determined by the pilot ratio.

带先导开启平衡阀用于控制超越负载工况。油液从②口到①口单向自由流动；油液经直动，先导辅助从①口溢流到②口，③口是溢流辅助控制口，按控制比降低溢流功能的有效设定值。

FEATURES

特性

Counterbalance valves should be set at least 1.3 times the maximum load induced pressure

最大设定压力至少为最大负载压力的1.3倍。

Backpressure at port ② adds to the effective relief setting at a ratio of 1 plus the pilot ratio times the backpressure

②口的背压按"控制比+1"的倍数加到溢流阀的设定值上即增加值 = (1+控制比) × 压力值。

Reseat exceeds 85% of set pressure when the valve is standard set. Setting lower than the standard set pressure may result in lower reseal percentages.

标准设定时闭合压力值大于设定压力值的85%；低于标准设定则闭合压力值的百分比相应降低。

Factory pressure setting established at 30cc/min (2 in³/min).

工厂的设定是指当溢流阀开启（流量为30cc/min）时的压力。

SYMBOL

机能符号

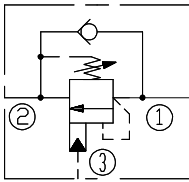

PRESSURE DROP VS.FLOW

性能图

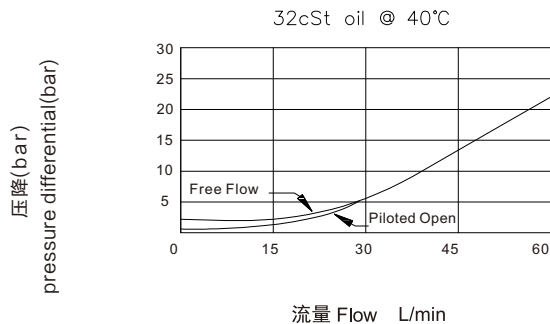

SPECIFICATIONS

技术参数

最大设定值Max.Setting : (HSCBCA)280Bar / (HSCBCG) 350bar

最大负载(Max. Recommended Load Pressure at Max. Setting):
在最大设定时所能承受的最大负载压力: 215bar HSCBCA
270bar HSCBCG

流量Flow : 60L/Min

内泄漏 Internal Leakage: 5drops/min

控制比Pilot Ratio: (HSCBCA)3:1/(HSCBCG)4.5:1

油液 Fluids: Mineral-based fluids with viscosities of 7.4 to 420 cSt.

插孔 Cavity: Sun T-11A see page 127

阀块材料Body Material: 钢材允许使用最大压力350bar
Steel rated at 350bar

INSTALLATION DIMENSIONS 安装尺寸

Turn adjustment clockwise to decrease setting and release load
顺时针方向旋转螺杆减少设定压以致卸载

Unit=Millimeters

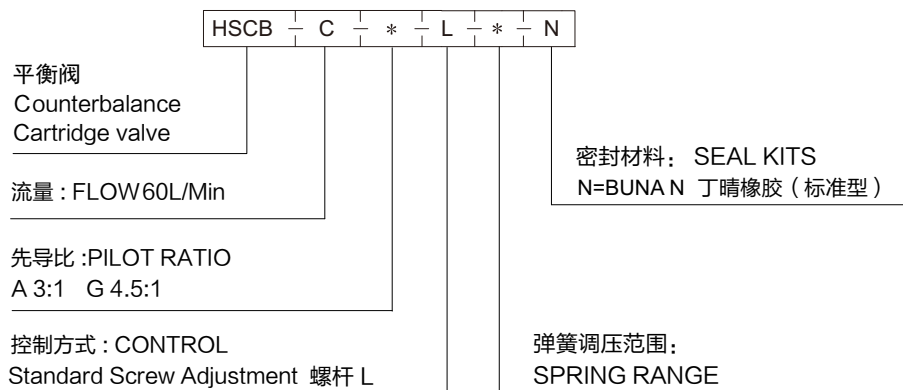
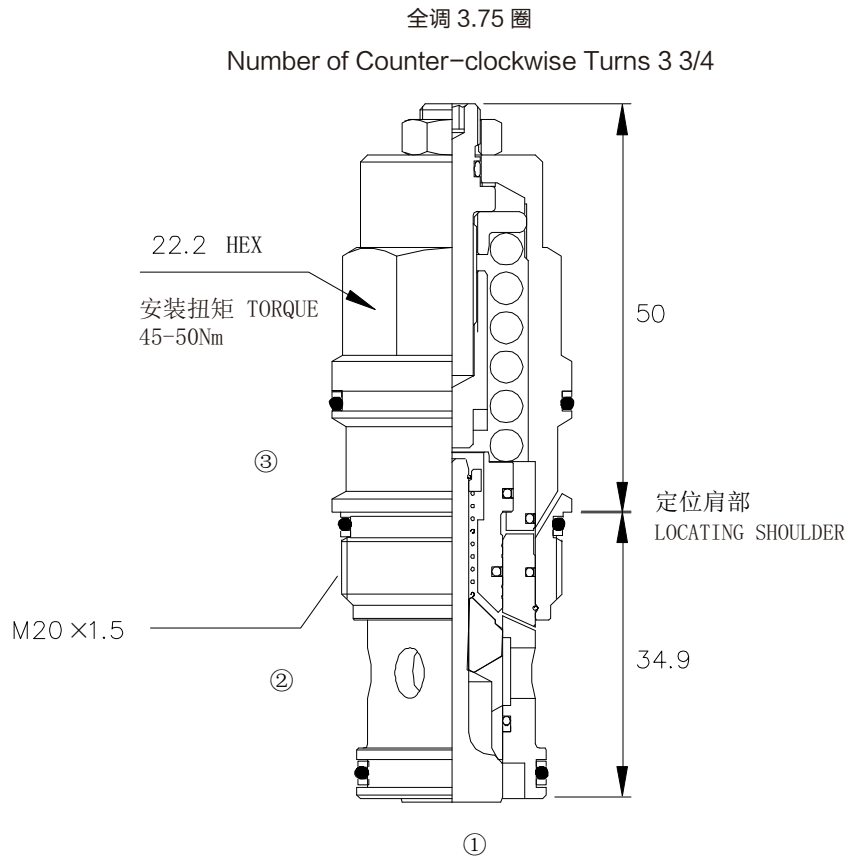

弹簧调压 HSCBCA:

H=1000-4000psi(70-280bar)
Preset: 3000psi(210bar) (Check:1.7bar)
I =400-1500psi(28-105bar)
Preset: 1000psi(70bar) (Check:1.7bar)
A=1000-4000psi(70-280bar)
Preset: 3000psi(210bar) (Check:0.3bar)
B=400-1500psi(28-105bar)
Preset:1000psi(70bar) (Check:0.3bar)

弹簧调压 HSCBCG:

J=2000-5000psi(140-350bar)
Preset: 3000psi(210bar) (Check:1.7bar)
K=1000-2500psi(70-175bar)
Preset: 2000psi(140bar) (Check:1.7bar)
C=2000-5000psi(140-350bar)
Preset: 3000psi(210bar) (Check:0.3bar)
D=1000-2500psi(70-175bar)
Preset: 2000psi(140bar) (Check:0.3bar)