

HSV08-40

二位四通电磁阀 滑阀型

Four-Way, Two-Position, Spool-Type
Cartridge Solenoid Valve

OPERATION

工作原理

When de-energized, the valve allows flow from ① to ④ and from ② to ③.
When energized, the cartridge's spool shifts to allow flow from ① to ② and from ③ to ④.
失电时，①和④通，②和③通；
得电时，①和②通，③和④通。

SYMBOL

机能符号

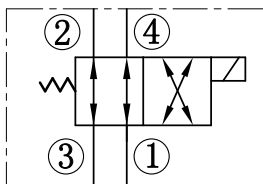

PRESSURE DROP VS.FLOW

性能图

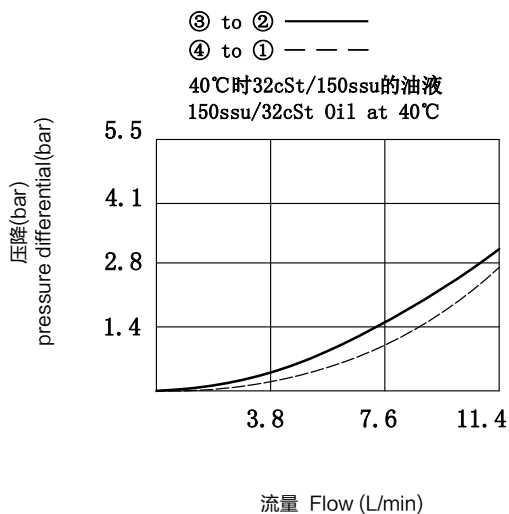

FEATURES

特性

- Continuous-duty solenoid
- Optional coil voltages and terminations
- Manual override option
- Efficient wet-armature construction
- Industry common cavity
- Compact size
- 可持续工作的电磁铁
- 可选线圈电压和终端
- 可带手动卸荷
- 高效能的电磁铁结构
- 工业通用插孔
- 结构紧凑

SPECIFICATIONS

技术参数

工作压力 Working Pressure : 207bar
流量 Flow Rate: 参见性能图
 See Pressure Drop VS.Flow graph
内泄漏 Internal Leakage: <82ML/min. Max at 207bar
温度范围 Temperature Range: -30°C+120°C
线圈电压范围 Coil Rating:
 90% to 110% of Rated Voltage
过滤 Filtration:
 Critical Application-ISO 18/16/13
 Non-Critical Application-ISO 19/17/14
介质 Fluids: 矿物油 Mineral-based fluids
插孔 Cavity: 08-4

INSTALLATION DIMENSIONS 安装尺寸

Coil Must Be Installed With Lettering Up
安装线圈时字母必须朝上

Unit=Millimeters

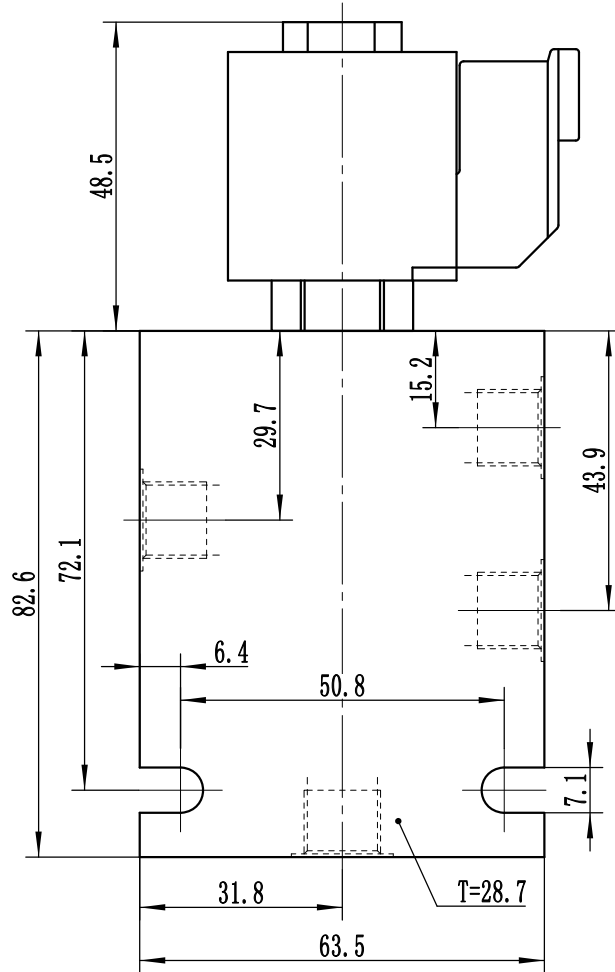
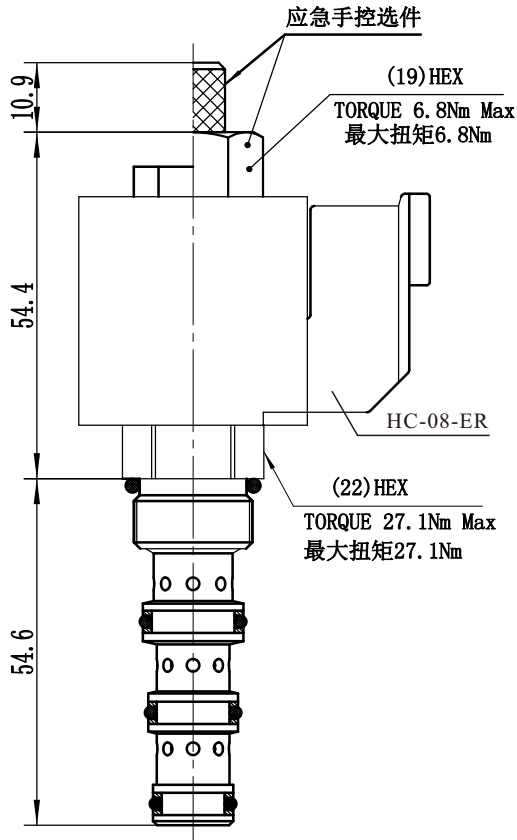

HSV08-40 - * * * * *

M=Manual Override 手动卸荷
Omit for standard 省略为常规

BODY PORTING 阀块油口

6T=SAE6

2B=G1/4

3B=G3/8

Other Porting is Available
其它螺纹油口也是可以选择的
(Omit of Cartridge only
省略为不带阀块)

密封材料

N=Nitrile Rubber Buna 丁晴橡胶(标准型)

COIL CONNECTION 线圈连接

D=Double Lead 双线

H=Hirschmann 三插

ER=Deutsch Connector

(Water proof Coil)

德意志插座(防水线圈)

VOLTAGE 电压

1=12V Volt DC

2=24V Volt DC

3=110V Volt AC

4=220V Volt AC