

SVK10 多回路选择阀

SVK10 FLOW DIVERTERS

符号 SYMBOL

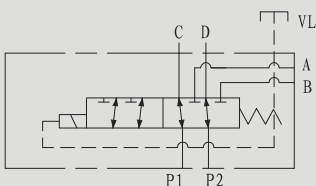

技术参数 Technical data

型号 Model	SVK10
最大流量 (L/min) Max Flow rate (L/min)	80
最大工作压力 (Mpa) Max operating pressure (MPa)	25
阀体 (材料) 表面处理 Valve body (Material) Surface treatment	(铸件) 表面磷化处理 / (casting) phosphating surface
油液清洁度 Oil cleanliness	NAS1638 9 级和 ISO4406 20/18/15 级 NAS1638 class 9 and ISO4406 class 20/18/15

特性曲线 (在使用 HLP46 , $\vartheta_{\text{油}}=40\text{ }^{\circ}\text{C} \pm 5\text{ }^{\circ}\text{C}$ 时测得) Characteristic curves (measured with HLP46 , $\text{Voil}=40\text{ }^{\circ}\text{C} \pm 5\text{ }^{\circ}\text{C}$)

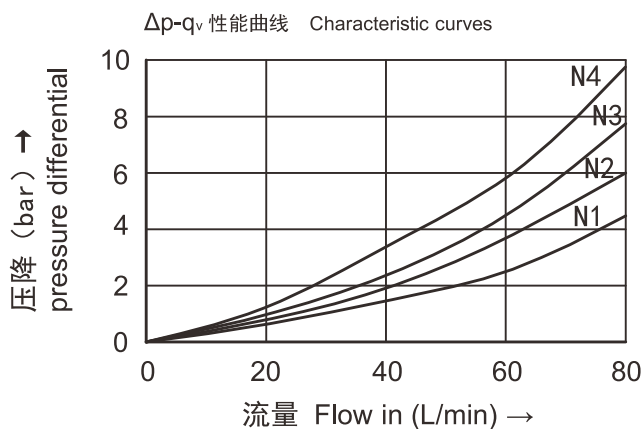

安装尺寸 Installation Dimensions

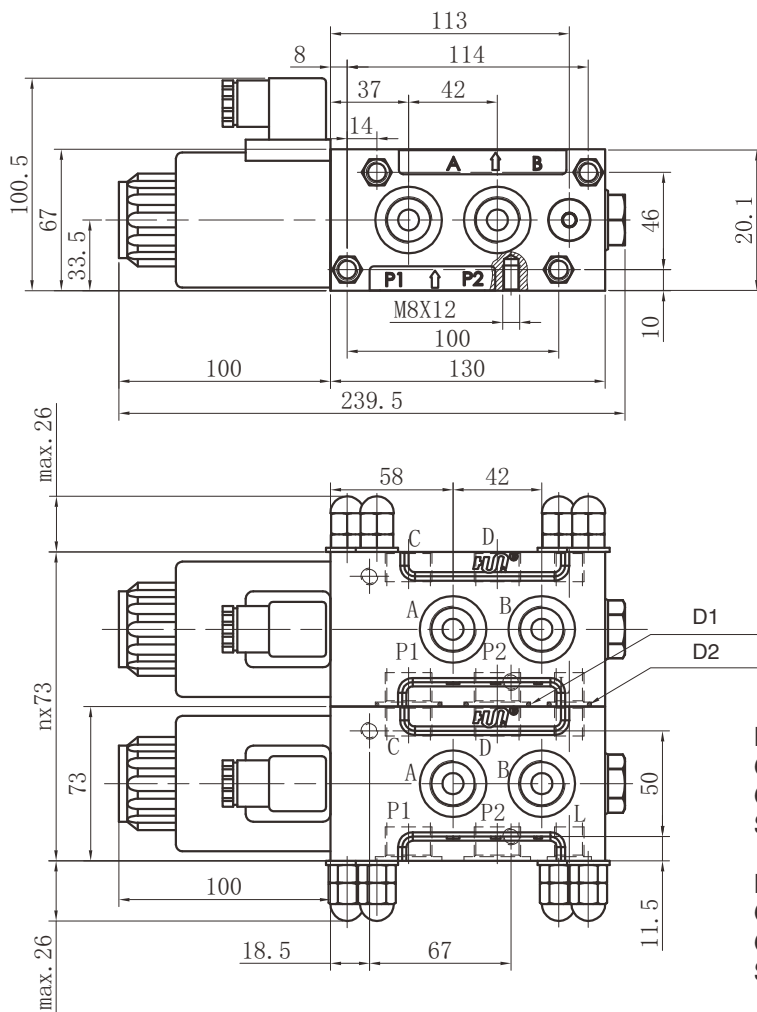

D1.0 型圈 /D1.0-Ring
 G1/2、M22X1.5= Φ 26.5X2.65
 G3/4、M27X2= Φ 32X2
 SAE10= Φ 29X2.65

D2.0 型圈 /D2.0-Ring
 G1/2、M22X1.5= Φ 17X2
 G3/4、M27X2= Φ 17X2
 SAE10= Φ 16X1.5



型号 Model

螺纹连接 Threaded connection
 G 1/2 G 3/4 SAE 10

电压 Voltage DC12;DC24

Z5L= 带灯大方形插头
 Z5L=Large quadrate plug with light

附加说明
 For further details

叠加的元件的个数 QTY of units
 N1=1 个(one unit) N2=2 个(two units)
 N3=3 个(three units) N4=4 个(four units)