

HSV10-34

二位三通电磁阀 滑阀型

Three-Way, Two-Position, Spool-Type Cartridge Solenoid Valve

OPERATION

工作原理

When de-energized, the valve allows flow from ② to ①, while blocking flow at ③. When energized, the cartridge's spool shifts to allow flow from ② to ③, while blocking flow at ①

失电时，②和①通，与③不通；

得电时，②和③通，与①不通；

手控应急 Operation of Manual Override Option:

To override, push button in, twist counterclockwise 180° and release.

In this position, valve will remain detented in the shifted condition.

To return to normal operation, push button in, twist clockwise 180° and release. Override will be detented in this position.

应急手动操控方法：要进行应急操作时，先按下旋钮，然后逆时针旋转 180° 后松开，2 与 3 通，与 1 不通；

要恢复操作，按下按钮顺时针旋转 180° 后松开，返回到常态。

SYMBOL

机能符号

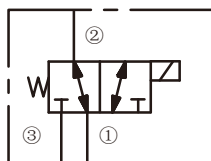

FEATURES

特性

- Continuous-duty solenoid. · 可持续工作的电磁铁。
- Efficient wet-armature construction. · 高效能电磁铁结构。
- Hardened seat for long life. · 长寿命的阀。
- Industry common cavity. · 工业通用插孔。
- Compact size · 结构紧凑。

PRESSURE DROP VS.FLOW

性能图

② to ① ——— De-energized; 不通电

② to ③ - - - - - Energized; 通电

38°C时150 ssu/32 cSt的油液 150 ssu/32 cSt Oil at 38°C

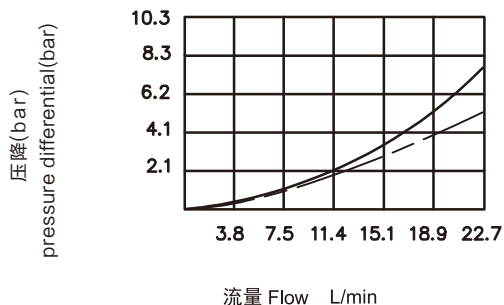

SPECIFICATIONS

技术参数

最大工作压力 Max. Operating Pressure): 207Bar

流量Flow rate(L/min): 参见性能图See Pressure Drop VS.Flow graph

内泄漏 Internal Leakage:82ml/min max. at 207bar

介质温度范围 Fluid temperature range: -30 °C to +120°C

线圈电压范围Coil Rating: 90% to 110% Of Rated Voltage

过滤Filtration:

Critical Application – ISO 18/16/13

Non-Critical Application – ISO 19/17/14

介质 Fluids: 矿物油。其它流体请咨询工厂。

Mineral-based fluids.

For other fluid compatibility,consult factory.

插孔 Cavity: 10-3

阀块材料Body Material:

6061-T6铝，允许使用最大压力207bar

钢材允许使用最大压力350bar

Anodized 6061-T6 aluminum alloy rated at 207bar

Steel rated at 350bar

INSTALLATION DIMENSIONS 安装尺寸

Coil Must Be Installed With Lettering Up
安装线圈时字母必须朝上

Unit=Millimeters

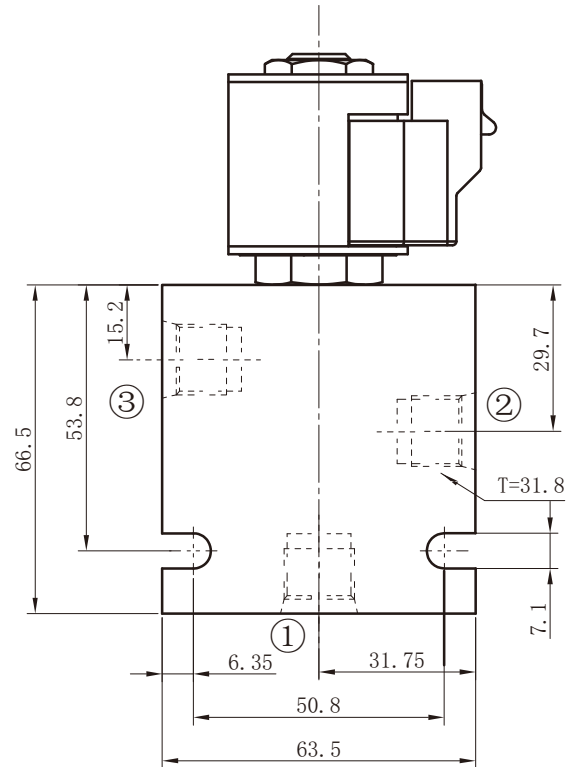
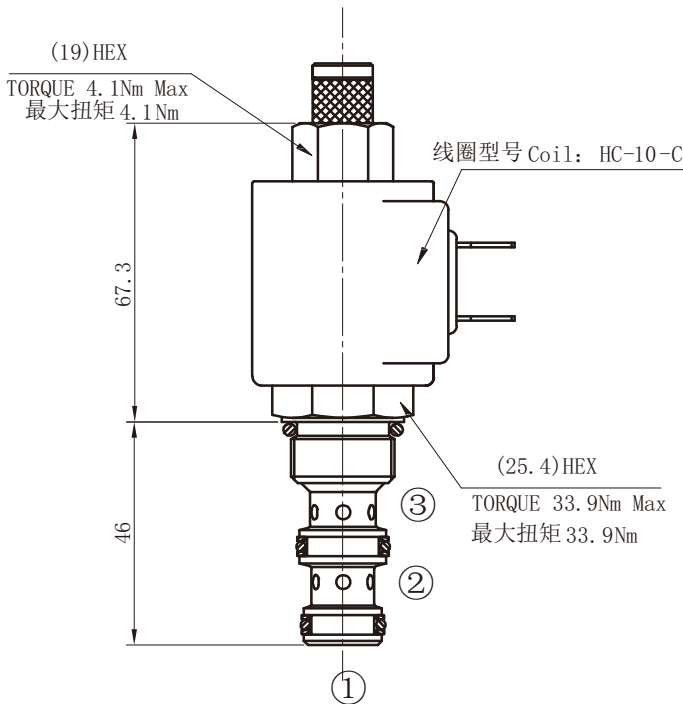

HSV10-34 * - * - * - * - *	
电磁阀 Solenoid Valve	BODY PORTING 阀块油口
S=Screen 过滤网	6T=SAE6
Omit for standard 省略为常规	8T=SAE8
M=Manual Override 手动卸荷	3G=G3/8
Omit for standard 省略为常规	4G=G1/2
油封 Seal Kits	Other Porting is Available
无 = 丁晴橡胶 (标准型)	其它螺纹油口也是可以选择的
Omit for Buna N (standard)	(Omit for Cartridge only
	省略为不带阀块)
VOLTAGE 电压	COIL CONNECTION 线圈连接
1=12V Volt DC	D=Double Lead 双线
2=24V Volt DC	H=Hirschmann 三插
3=110V Volt AC	ER=Deutsch Connector
4=220V Volt AC	(Water proof Coil)
	德意志插座 (防水线圈)