

HVC10 二位三通电磁换向阀

HVC10 SERIES DIRECTIONAL VALVES LINE MOUNTING

符号 SYMBOL

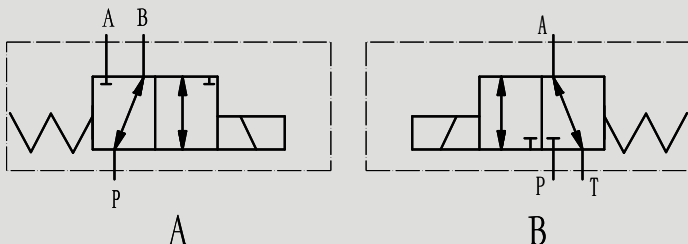

▶ 技术参数 Technical data

型号 Model	HVC10
最大流量 (L/min) Max Flow rate (L/min)	80
最大工作压力 (Mpa) Max operating pressure(MPa)	25
阀体 (材料) 表面处理 Valve body (Material) Surface treatment	(铸件) 表面磷化处理 / (casting) phosphating surface
油液清洁度 Oil cleanliness	NAS1638 9 级和 ISO4406 20/18/15 级 NAS1638 class 9 and ISO4406 class 20/18/15

▶ 特性曲线 (在使用 HLP46 , 油温=40 °C ± 5 °C 时测得)

Characteristic curves (measured with HLP46 , $T_{oil}=40\text{ }^{\circ}\text{C} \pm 5\text{ }^{\circ}\text{C}$)

Δp - q_v 性能曲线 Characteristic curves

1=P1-A;B-P2 2=P1-C;D-P2

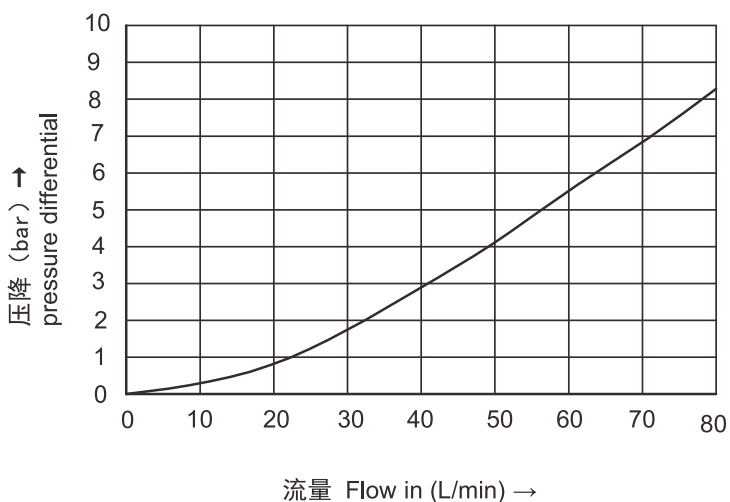

▶ 安装尺寸 Installation Dimensions

Catalogue 2022

HVC10A

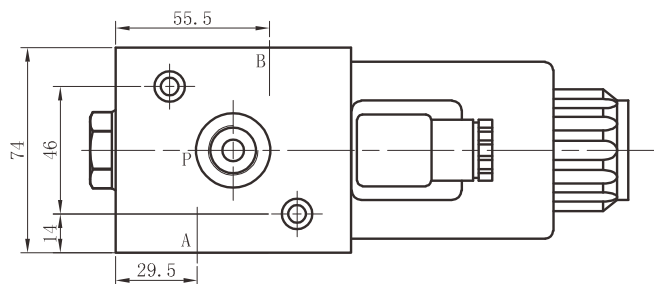
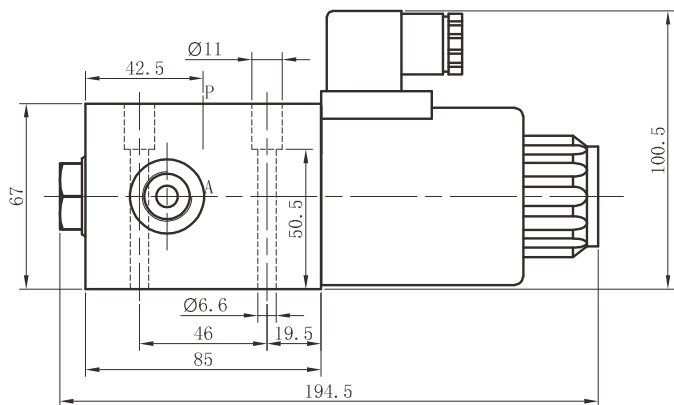

HVC10B

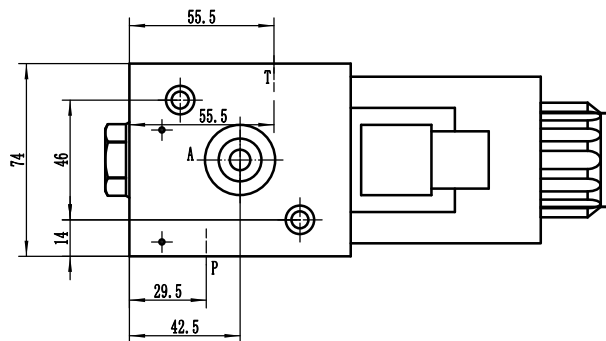
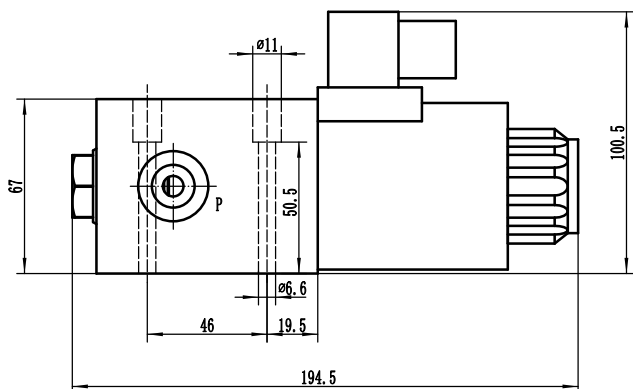

HVC10	A	*	*	Z5L	*
-------	---	---	---	-----	---

型号
Model

机能符号：
A型 B型
Spool symbols:
Type A Type B

螺纹连接 Threaded connection
G 1/2 SAE 8

附加说明
For further details

Z5L= 带灯大方形插头
Z5L=Large quadrate plug with light

电压 Voltage DC12;DC24