

HSV10-24

二位二通电磁阀 滑阀型

Two-Way, Two-Position, Spool-Type
Cartridge Solenoid Valve

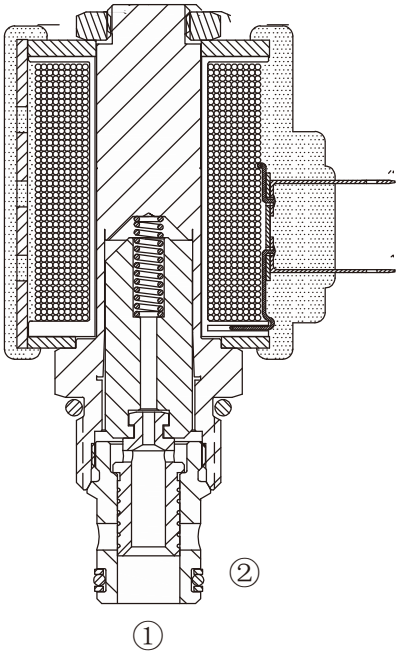

OPERATION

工作原理

When energized, the valve allows flow in both directions ,
When de-energized, the cartridge's spool shifts to block flow in either direction.

得电时，此阀允许油液双向流动；

断电时，阀芯移动，从而双向截止油液流动；

手控应急 Operation of Manual Override Option:

To override, push button in, twist counterclockwise 180° and release.
In this position, valve will remain open in a detented condition.

To return to normal operation, push button in, twist clockwise 180° and release. Override will be detented in this position.

应急手动操控方法：要进行应急操作时，先按下旋钮，然后逆时针旋转 180° 后松开，阀口打开；

要恢复操作，按下按钮顺时针旋转 180° 后松开，返回到常态。

SYMBOL

机能符号

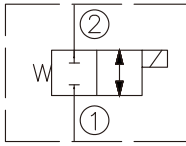

PRESSURE DROP VS.FLOW

性能图

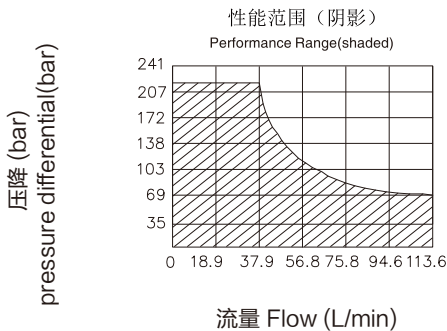
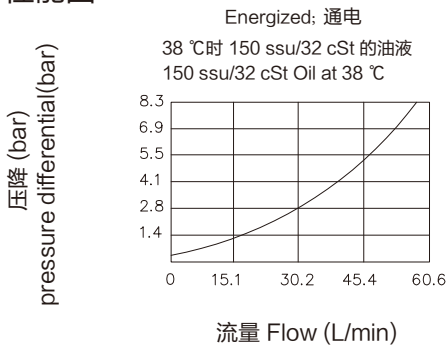

FEATURES

特性

- Continuous-duty solenoid. · 可持续工作的电磁铁。
- Efficient wet- armature construction. · 高效能电磁铁结构。
- Hardened seat for long life. · 长寿命的阀。
- Industry common cavity. · 工业通用插孔。
- Compact size. · 结构紧凑。

SPECIFICATIONS

技术参数

最大工作压力 Max. Operating Pressure : 207Bar

流量 Flow rate (L/min): 参见性能图 See Pressure Drop VS. Flow graph

内泄漏 Internal Leakage: 82cc/min

Our ideal leakage < 82ml/min

介质温度范围 Fluid temperature range: -30 °C to +120 °C

线圈电压范围 Coil Rating: 90% to 110% Of Rated Voltage

过滤 Filtration:

Critical Application - ISO 18/16/13

Non-Critical Application - ISO 19/17/14

介质 Fluids: 矿物油。其它流体请咨询工厂。

Mineral-based fluids.

For other fluid compatibility, consult factory.

插孔 Cavity: 10-2

阀块材料 Body Material:

6061-T6铝，允许使用最大压力207bar

钢材允许使用最大压力350bar

Anodized 6061-T6 aluminum alloy rated at 207bar

Steel rated at 350bar

INSTALLATION DIMENSIONS 安装尺寸

Coil Must Be Installed With Lettering Up
安装线圈时字母必须朝上

Unit=Millimeters

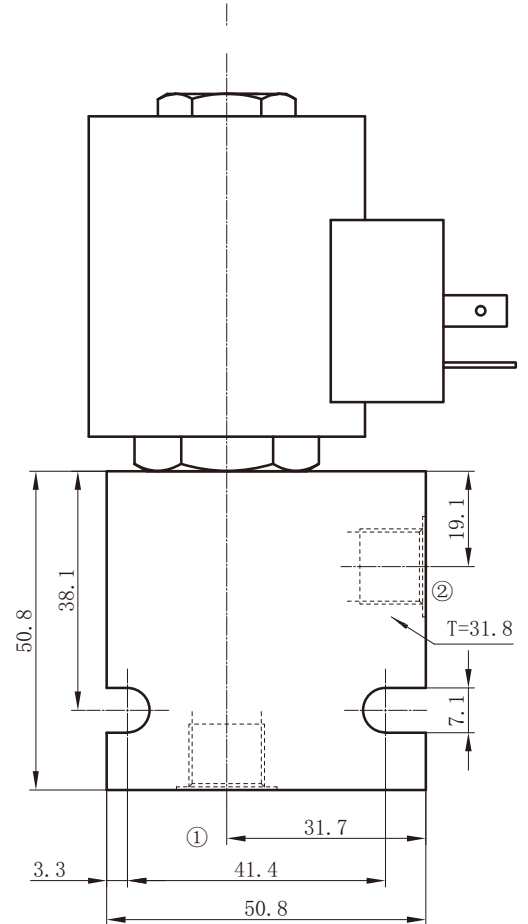
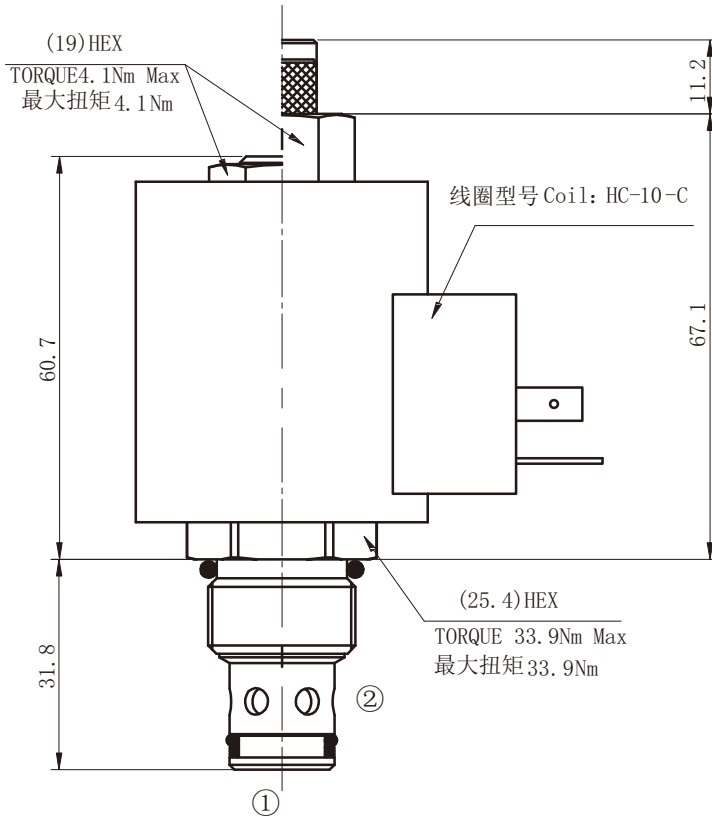

HSV10-24 * * * * *	
电磁阀 Solenoid Valve	BODY PORTING 阀块油口 6T=SAE6 8T=SAE8 3G=G3/8 4G=G1/2 Other Porting is Available 其它螺纹油口也是可以选择的 (Omit for Cartridge only 省略为不带阀块)
M=Manual Override 手动卸荷 Omit for standard 省略为常规	COIL CONNECTION 线圈连接 D=Double Lead 双线 H=Hirschmann 三插 ER=Deutsch Connector (Water proof Coil) 德意志插座 (防水线圈)
油封 Seal Kits 无 = 丁晴橡胶 (标准型) Omit for Buna N (standard)	
VOLTAGE 电压 1=12V Volt DC 2=24V Volt DC 3=110V Volt AC 4=220V Volt AC	