

# HSV08-24

## 二位二通电磁阀 滑阀型

### Two-Way, Two-Position, Spool-Type Cartridge Solenoid Valve

#### OPERATION

##### 工作原理

When energized, the valve allows flow in both directions ,  
When de-energized, the cartridge's spool shifts to block flow in either direction.

得电时，此阀允许油液双向流动；

断电时，阀芯移动，从而双向截止油液流动；

手动应急 Operation of Manual Override Option:

To override, push button in, twist counterclockwise

180° and release. In this position, valve will remain open in a detented condition. To return to normal operation, push button in, twist clockwise 180° and release. Override will be detented in this position.

应急手动操控方法：要进行应急操作时，先按下旋钮，然后逆时针旋转180°后松开，阀口打开；

要恢复操作，按下按钮顺时针旋转180°后松开，返回到常态。

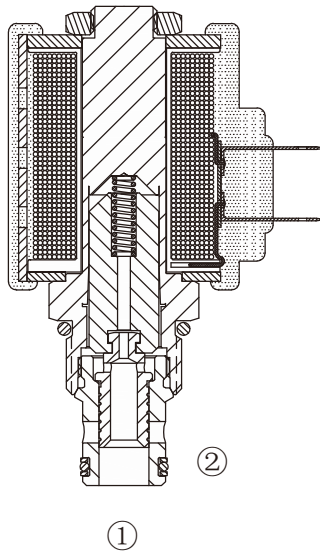

#### SYMBOL

##### 机能符号

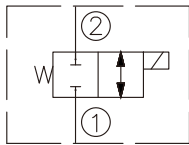

#### PRESSURE DROP VS.FLOW

##### 性能图

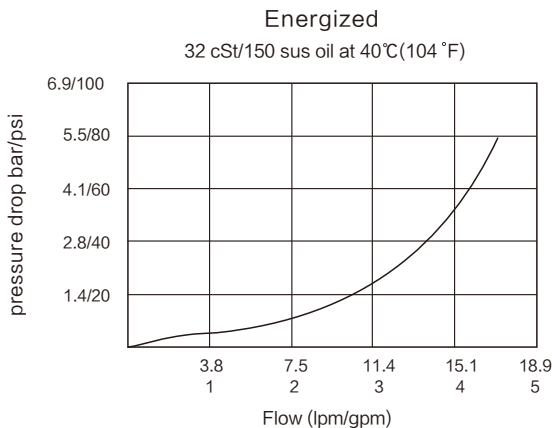

#### FEATURES

##### 特性

- Continuous-duty solenoid. · 可持续工作的电磁铁。
- Efficient wet-armature construction. · 高效能电磁铁结构。
- Hardened seat for long life. · 长寿命的阀。
- Industry common cavity. · 工业通用插孔。
- Compact size · 结构紧凑。

#### SPECIFICATIONS

##### 技术参数

**最大工作压力 Max. Operating Pressure :** 207Bar

**流量 Flow rate (L/min):** 参见性能图 See Pressure Drop VS. Flow graph

**内泄漏 Internal Leakage:** 82ml/min max. at 207bar

**介质温度范围 Fluid temperature range:** -30 °C to +120°C

**线圈电压范围 Coil Rating:** 90% to 110% Of Rated Voltage

**过滤 Filtration:**

Critical Application – ISO 18/16/13

Non-Critical Application – ISO 19/17/14

**介质 Fluids:** 矿物油。其它流体请咨询工厂。

Mineral-based fluids.

For other fluid compatibility, consult factory.

**插孔 Cavity:** 08-2

**阀块材料 Body Material:**

6061-T6铝，允许使用最大压力207bar

钢材允许使用最大压力350bar

Anodized 6061-T6 aluminum alloy rated at 207bar

Steel rated at 350bar

# INSTALLATION DIMENSIONS 安装尺寸

Coil Must Be Installed With Lettering Up  
安装线圈时字母必须朝上

Unit=Millimeters

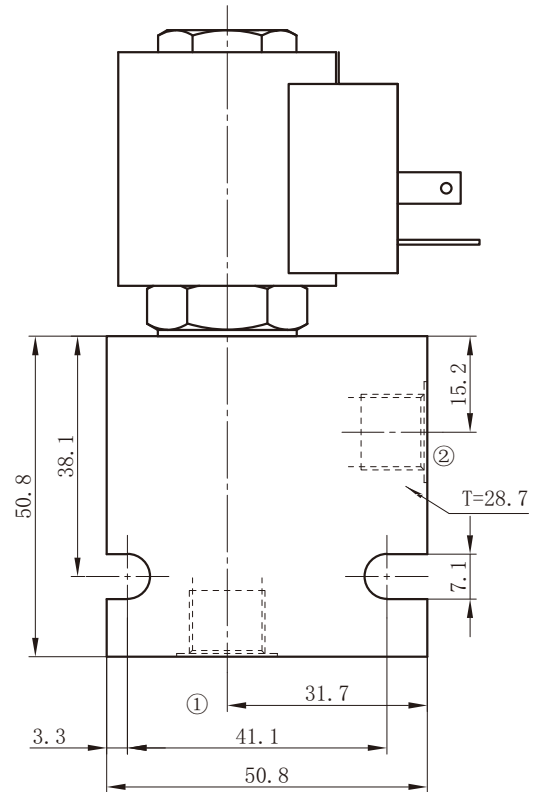
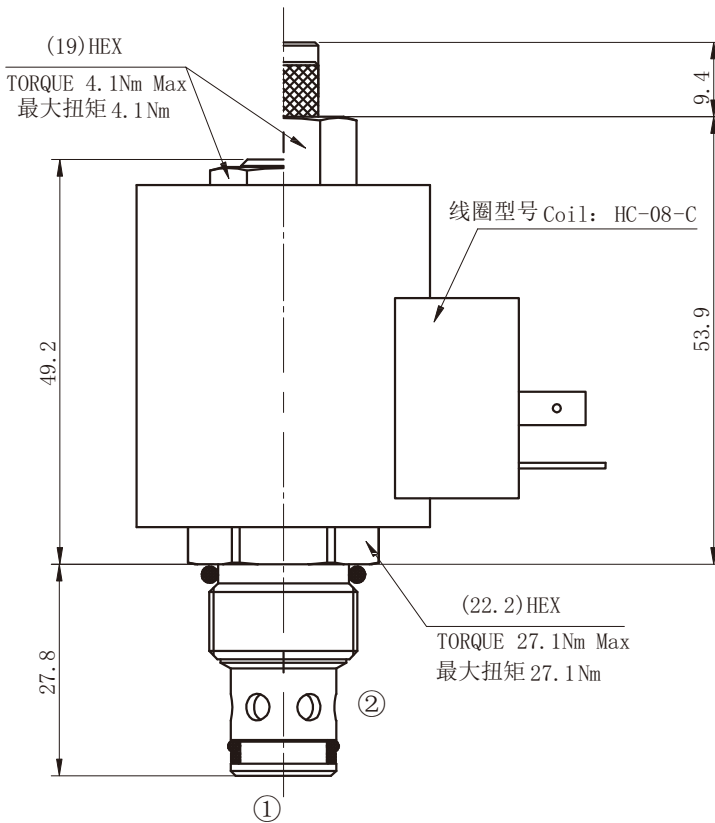

| HSV08-24- * - * - * - * - *  |   |
|--|---|
| 电磁阀 Solenoid Valve   | BODY PORTING 阀块油口   |
| S=Screen 过滤网<br>Omit for standard 省略为常规  | 6T=SAE6<br>8T=SAE8<br>3G=G3/8<br>4G=G1/2  |
| M=Manual Override 手动卸荷<br>Omit for standard 省略为常规                                | Other Porting is Available<br>其它螺纹油口也是可以选择的<br>( Omit for Cartridge only<br>省略为不带阀块 )               |
| 油封 Seal Kits<br>无 = 丁晴橡胶 ( 标准型 )<br>Omit for Buna N (standard)                   | COIL CONNECTION 线圈连接  |
| VOLTAGE 电压<br>1=12V Volt DC<br>2=24V Volt DC<br>3=110V Volt AC<br>4=220V Volt AC | D=Double Lead 双线<br>H=Hirschmann 三插<br>ER=Deutsch Connector<br>(Water proof Coil)<br>德意志插座 ( 防水线圈 ) |