

DWHG25型电液换向阀

DWHG25 SERIES SOLENOID
PILOT OPERATED
DIRECTIONAL VALVES

DWHG25 型电液换向阀是用电磁换向阀作为先导控制的滑阀式换向阀，用于控制液流的通断和流动方向。

DWHG25 series are solenoid pilot operated spool type valves . This series are used to control the start ,stop and direction of flow.

▶ 技术参数 Technical data

通径 Size	25	
最高工作压力 P A B(MPa) Max operating pressure P.A.B(MPa)	35	
T 口 (MPa) T Port (MPa)	控制油外排 Externally drained	25
	控制油内排 Internally drained	交流 (AC)-10 直流 (DC)-16
Y 口 (MPa) Y Port (MPa)	控制油外排 Externally drained	交流 (AC)-10 直流 (DC)-16
	最小控制压力 (MPa) Min. Pilot pressure(MPa)	0.45-1
最大流量 (L/min)Max. flow rate(L/min)	650	
重量 (千克) Weight(KGS)	18	
阀体 (材料) 表面处理 Valve body (Material) Surface treatment	铸件 表面磷化处理 casting phosphating surface	
油液清洁度 /Oilcleanliness	NAS1638 9 级和 ISO4406 20/18/15 级 NAS1638 class 9 and ISO4406 class 20/18/15	

特性曲线: 4DWHG25... 型 (在使用HLP46, 油=40 °C ± 5 °C时测得)

Characteristic curves: Type 4DWHG25... (measured with HLP46 , Voil=40 °C ± 5 °C)

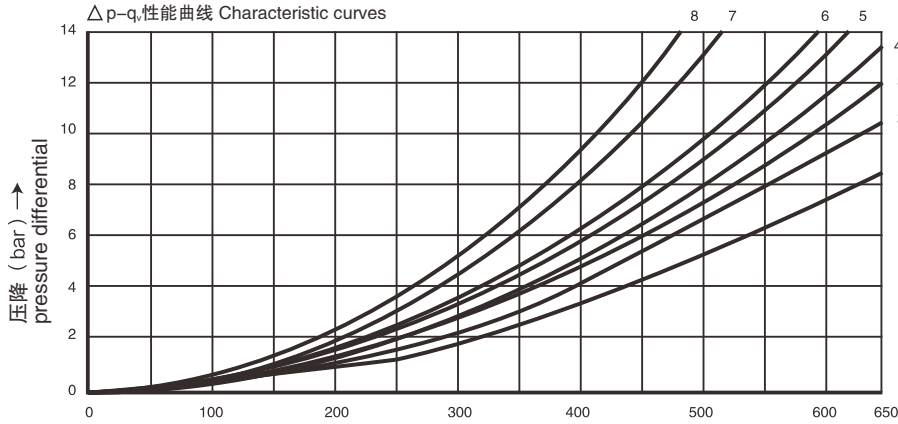

流量 Flow in (L/min) →

机能符号 Spool symbol	切换位置 Spool position			
	P-A	P-B	A-T	B-T
E	1	1	1	3
F	1	4	3	3
G	3	1	2	4
H	4	4	3	4
J	2	2	3	5

机能符号 Spool symbol	切换位置 Spool position			
	P-A	P-B	A-T	B-T
L	2	2	3	3
M	4	4	1	4
P	4	1	1	5
R	2	1	1	-

7 机能符号 G Spool symbol G
中位 P-T Central position P-T

8 机能符号 T Spool symbol T
中位 P-T Central position P-T

机能符号 Spool symbols

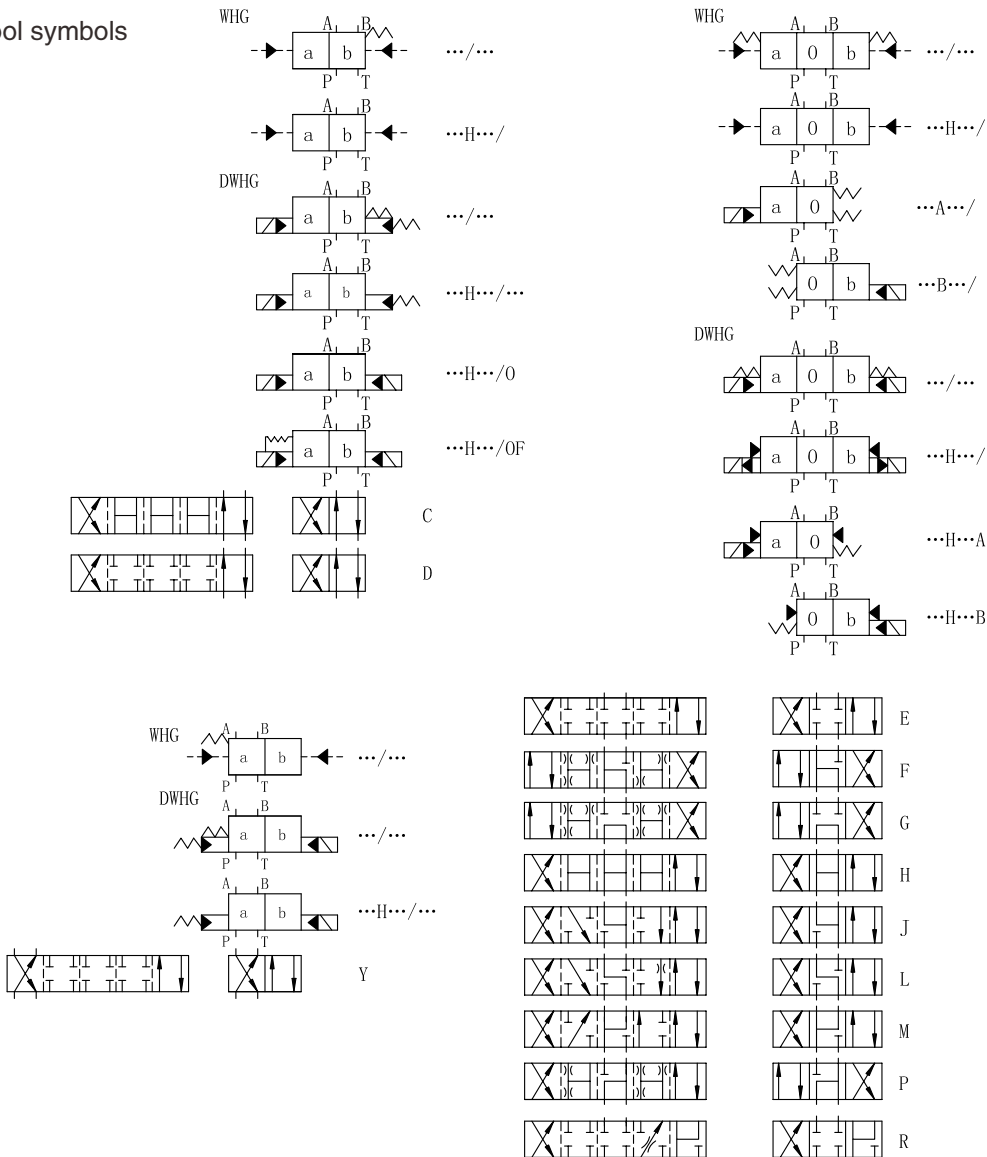

▶ 控制油内供与外供及内排与外排的说明 Pilot fluid supply

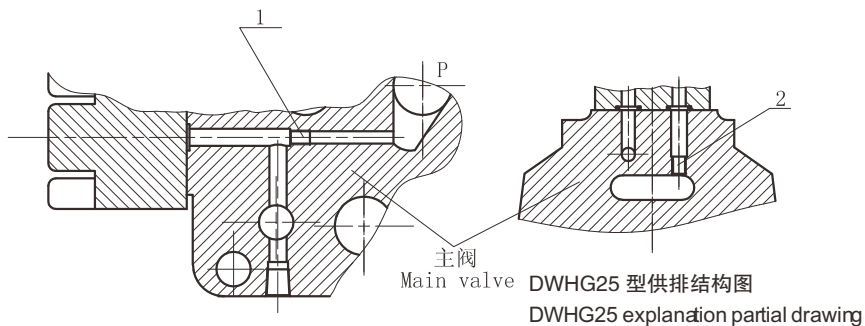

4DWHG25 型

- 1、内供与外供转换：拆下端盖，装上M6螺钉 1 外供，拆下 M6 螺钉 2 成内供。
- 2、内排与外排转换：将主阀顶上T孔中的 M6 螺钉 2 拆下为内排，装上为外排。

注意事项：内供时必须把底板上 X 口堵住，内排时必须把底板上 Y 口堵住。

3、4DWHG25

- (1) Internal pilot and external pilot:
Removing the sideward cover, installing M6 screw 1 is external pilot, unscrew the M6 screw 2 is internal pilot.
- (2) Internal drain and external drain:
Removing the M6 screw 2 in the "T" port on the top of main valve is internal drain, installing the M6 screw 2 is external drain.

NOTE : 1.The "X" port on the base plate must be plugged if internal pilot.
2.The "Y" port on the base plate must be plugged if internal drain.

4DWHG25 外型尺寸 4DWHG25 Overall Dimensions

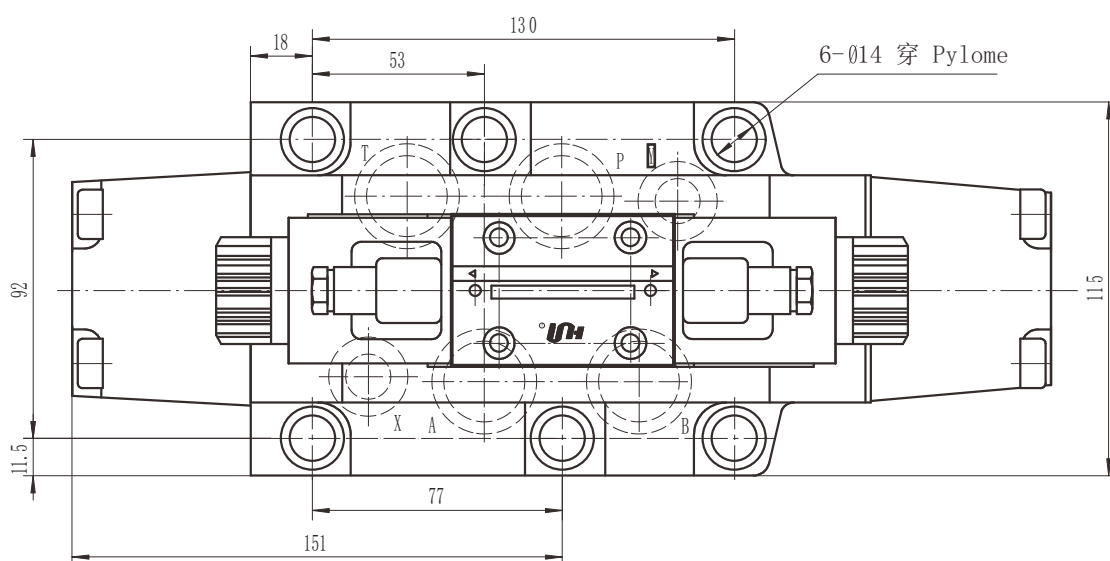
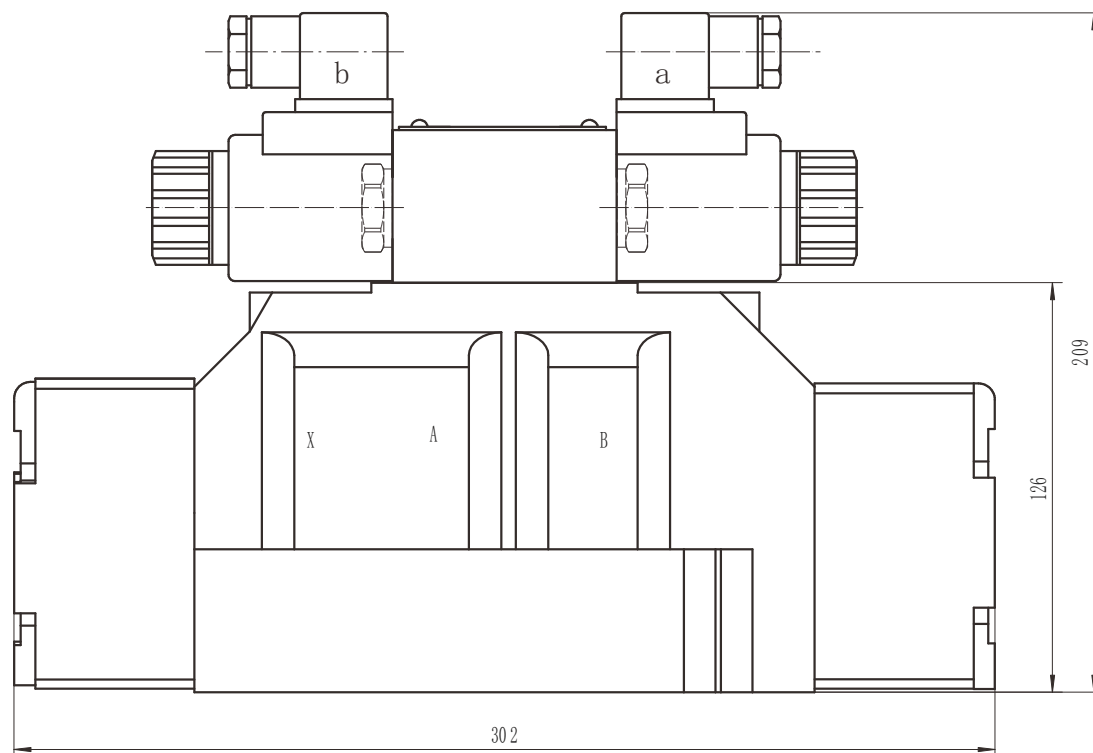

阀固定螺钉

6 个 M12X60 GB/T 70.1-12.9 级 拧紧扭矩 $M_a=130\text{Nm}$

A.B.P.T 口 O 型圈: $\phi 34 \times 3.1$

X.Y 口 O 型圈: $\phi 25 \times 3.1$

Valve's set screw

6 of M12 \times 60 GB/T70.1-12.9 Tightening torque $M_a=130\text{Nm}$.

O-ring for P.T.A.B Port: $\phi 34 \times 3.1$

O-ring for X.Y Port: $\phi 25 \times 3.1$

底板安装尺寸 Installation dimensions

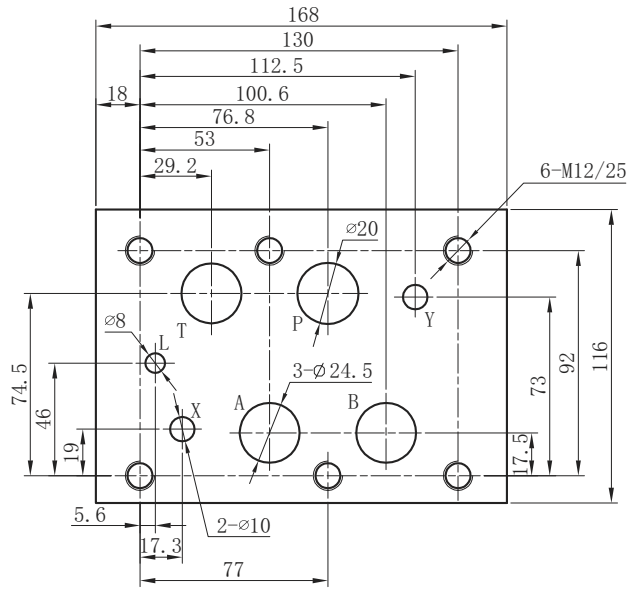

4DWHG25	E	60	/	*	DC24	N	*	/	*	Z5L	*	*	*	*
---------	---	----	---	---	------	---	---	---	---	-----	---	---	---	---

口径 25
Size 25

见滑阀机能符号
See the function symbol of spool valve

系列 60=16-32 口径
Series 60=Size 16-32

无 = 弹簧复位
O= 导阀无复位弹簧
OF= 导阀无复位弹簧, 带定位器
No code=With spring return
O=Without spring return
OF=Without spring return,with detent

电压 Voltage
DC12;DC24 ;AC110;AC220

N= 有故障检查按钮
N=With concealed manual override

无 = 外供外排型 E= 内供外排型
ET= 内供内排型 T= 外供内排型
No code=Externally pilot, externally drained
E=Internally pilot, externally drained
ET=Internally pilot, internally drained
T=Externally pilot, internally drained

附加说明
For further details
无 = 丁晴橡胶

V= 氟橡胶
No code = NBR seals
V=FPM seals

无标记 = 不带预压阀
P4.5= 带预压阀; 开启压力 0.45MPa
No code=Without preload valve
P4.5=With preload valve
cracking pressure is 0.45MPa

无标记 = 不带插入式阻尼器
(电磁换向阀 P 口节流)
B0.8= 节流孔径 0.8 B10= 节流孔径 1.0
B12= 节流孔径 1.2 B15= 节流孔径 1.5
No code if without plug-in throttleer
B0.8=Throttle orifice size 0.8
B10=Throttle orifice size 1.0
B12=Throttle orifice size 1.2
B15=Throttle orifice size 1.5

Z5L= 带灯大方形插头
ER= 德意志插头
Z5L= Large quadrate plug with light
ER=Deutsch Connector

无 = 没有调节器
S= 有调节器, 进口节流 S2= 有调节器, 出口节流
No code=Without pilot adjustment
S=With meter-in pilot adjustment
S2=With meter-out pilot adjustment